

# The Future of CMMI

Jay Douglass  
Software Engineering Institute  
Carnegie Mellon University  
Pittsburgh, PA 15213  
March 19, 2007



# Transition from V1.1 to V1.2 Status

## As reported to the SEI as of 12-31-06<sub>2</sub>

---

### **Introduction to CMMI Students**

**Registered for Upgrade Training – 1275**

**Upgrades Complete – 717**

### **Lead Appraisers and Instructors**

**Registered for Upgrade training – 621**

**Upgrade Complete – 419**



# CMMI Adoption Trends

## CMMI Web pages views in September 2006

- 360K/month
- Exceeded 24K/day

The following were the most downloaded files on the SEI Web site in September 2006:

- CMMI-DEV, V1.2 (PDF Version)
- CMMI V1.1 Overview Presentation
- CMMI V1.2 Overview Presentation
- CMMI-DEV, V1.2 (Word Version)
- CMMI V1.2 Model Changes Presentation

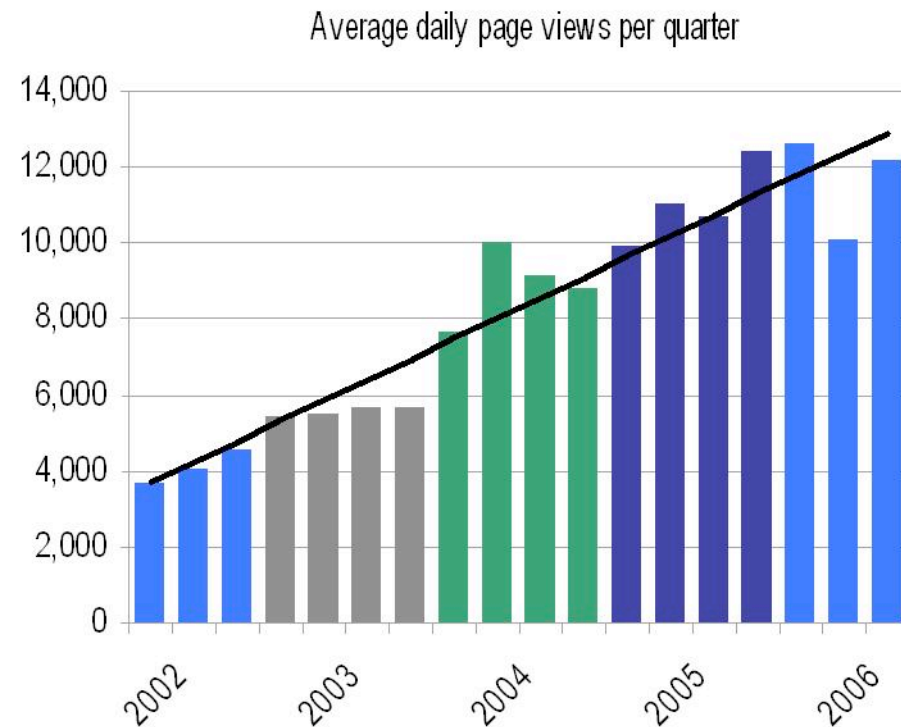

# CMMI Transition Status – 12/31/06

---

## Training

Introduction to CMMI – 59,434 trained

Intermediate CMMI – 2,367 trained

Introduction to CMMI Instructors – 477

SCAMPI Lead Appraisers – 684 trained

SCAMPI B&C-Only Team Lead -- 33

## Authorized

Introduction to CMMI V1.1/1.2 Instructors – 408/314

SCAMPI V1.1/1.2 Lead Appraisers – 455/328

SCAMPI B&C Team Leads -- 456



## Number of SCAMPI v1.1 Class A Appraisals Conducted by Quarter Reported as of 31 August 2006

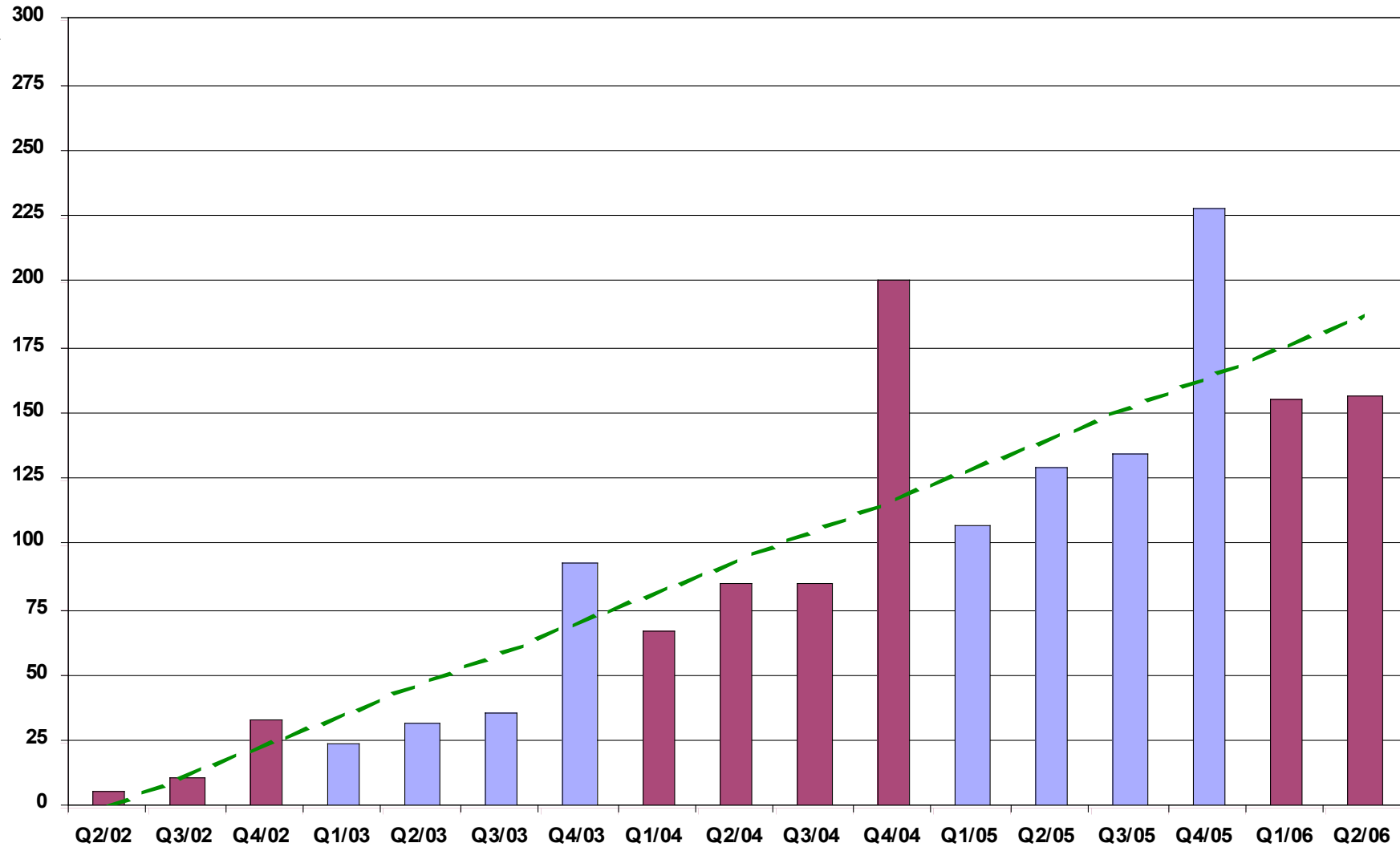

# Number of SCAMPI v1.1/v1.2 Class A Appraisals Conducted by Quarter Reported as of 31 December 2006

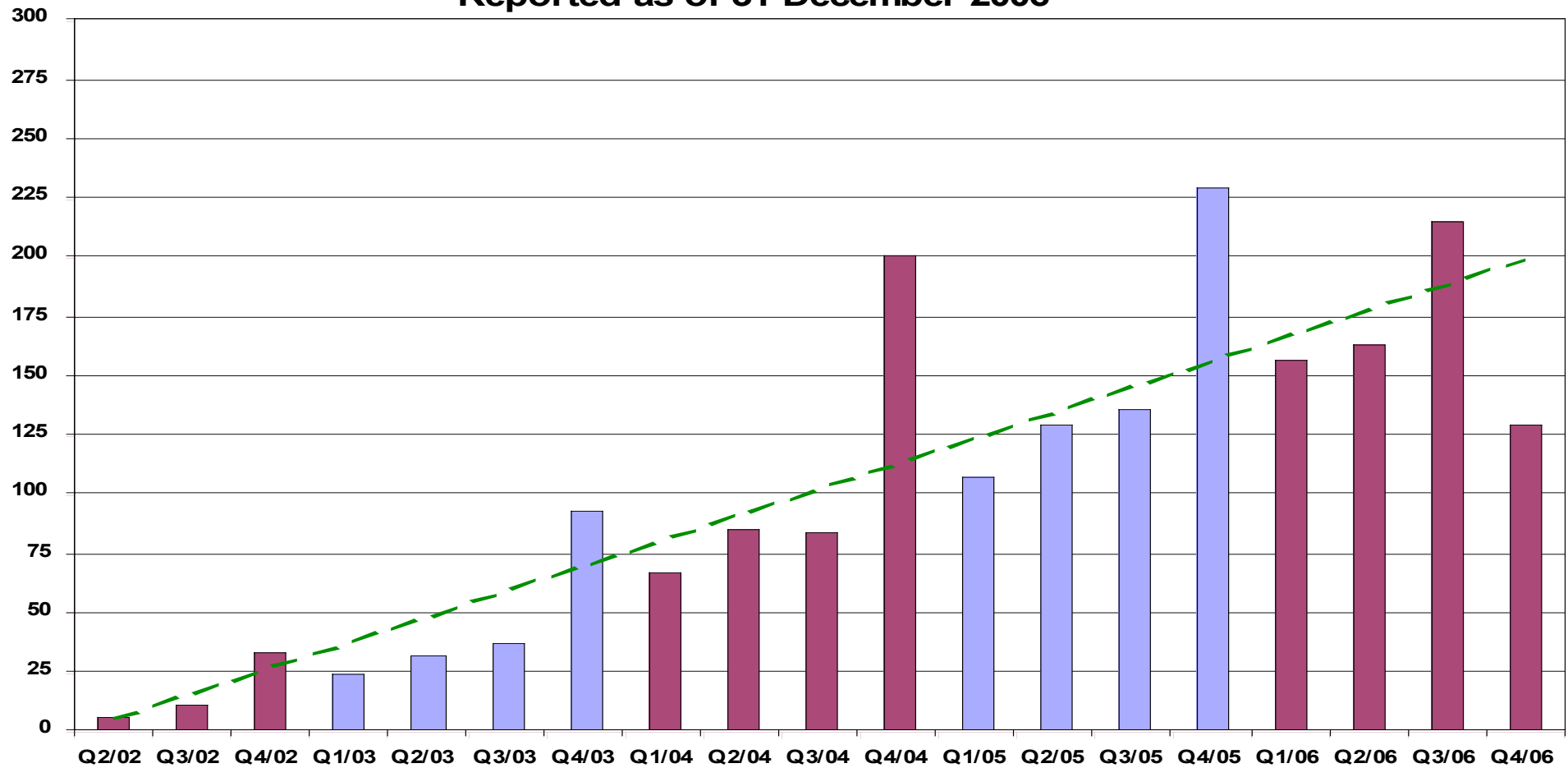

# Countries where Appraisals have been Performed and Reported to the SEI

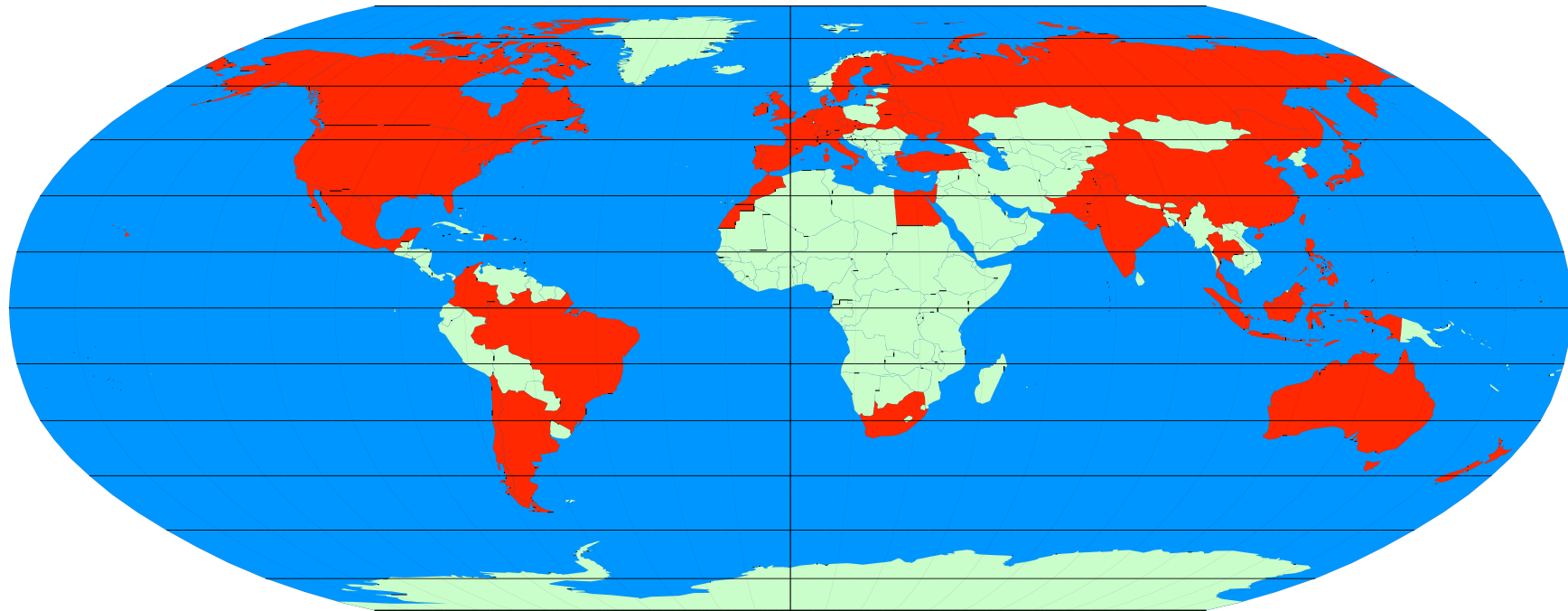

Argentina	Australia	Austria	<b>Bahrain</b>	Belarus	Belgium	Brazil	Canada
Chile	China	Colombia	Czech Republic	Denmark	<b>Dominican Republic</b>	Egypt	Finland
France	Germany	Hong Kong	India	<b>Indonesia</b>	Ireland	Israel	Italy
Japan	Korea, Republic of	Latvia	Malaysia	Mauritius	Mexico	<b>Morocco</b>	Netherlands
New Zealand	<b>Pakistan</b>	Philippines	Portugal	Russia	Singapore	Slovakia	South Africa
Spain	Sweden	Switzerland	Taiwan	Thailand	Turkey	Ukraine	United Kingdom
United States	Vietnam						

Red country name: New additions with this reporting



# Number of Appraisals and Maturity Levels Reported to the SEI by Country

Country	Number of Appraisals	Maturity Level 1 Reported	Maturity Level 2 Reported	Maturity Level 3 Reported	Maturity Level 4 Reported	Maturity Level 5 Reported	Country	Number of Appraisals	Maturity Level 1 Reported	Maturity Level 2 Reported	Maturity Level 3 Reported	Maturity Level 4 Reported	Maturity Level 5 Reported
Argentina	15	No	Yes	Yes	Yes	Yes	Korea, Republic of	56	Yes	Yes	Yes	Yes	Yes
Australia	23	Yes	Yes	Yes	Yes	Yes	Latvia	10 or fewer					
Austria	10 or fewer						Malaysia	15	No	No	Yes	No	Yes
Bahrain	10 or fewer						Mauritius	10 or fewer					
Belarus	10 or fewer						Mexico	10 or fewer					
Belgium	10 or fewer						Morocco	10 or fewer					
Brazil	39	No	Yes	Yes	Yes	Yes	Netherlands	10 or fewer					
Canada	18	No	Yes	Yes	No	Yes	New Zealand	10 or fewer					
Chile	10 or fewer						Pakistan	10 or fewer					
China	158	Yes	Yes	Yes	Yes	Yes	Philippines	14	No	Yes	Yes	No	Yes
Colombia	10 or fewer						Portugal	10 or fewer					
Czech Republic	10 or fewer						Russia	10 or fewer					
Denmark	10 or fewer						Singapore	10 or fewer					
Dominican Republic	10 or fewer						Slovakia	10 or fewer					
Egypt	10						South Africa	10 or fewer					
Finland	10 or fewer						Spain	25	No	Yes	Yes	No	Yes
France	65	Yes	Yes	Yes	Yes	Yes	Sweden	10 or fewer					
Germany	28	Yes	Yes	Yes	Yes	Yes	Switzerland	10 or fewer					
Hong Kong	10 or fewer						Taiwan	31	No	Yes	Yes	No	No
India	177	No	Yes	Yes	Yes	Yes	Thailand	10 or fewer					
Indonesia	10 or fewer						Turkey	10 or fewer					
Ireland	10 or fewer						Ukraine	10 or fewer					
Israel	10 or fewer						United Kingdom	42	Yes	Yes	Yes	Yes	No
Italy	10 or fewer						United States	598	Yes	Yes	Yes	Yes	Yes
Japan	155	Yes	Yes	Yes	Yes	Yes	Vietnam	10 or fewer					



# Combined Appraisal Opportunities

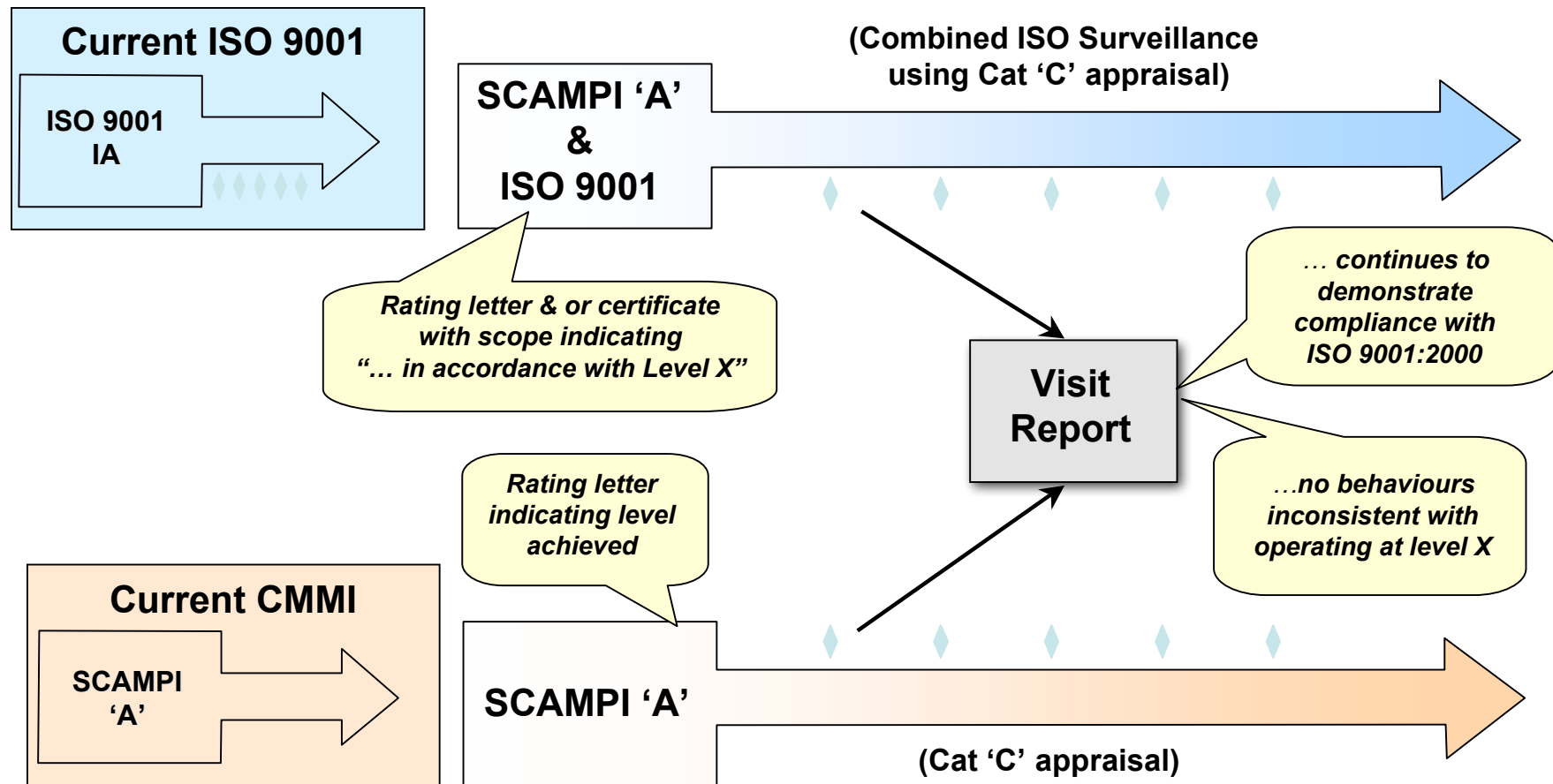

## Performance Results Summary

Improvements	Median	# of data points	Low	High
Cost	20%	21	3%	87%
Schedule	37%	19	2%	90%
Productivity	67%	16	11%	255%
Quality	50%	18	29%	132%
Customer Satisfaction	14%	6	-4%	55%
Return on Investment	4.8 : 1	14	2 : 1	27.7 : 1

- N = 25, as of 15 December 2005
- Organizations with results expressed as change over time



# CMMI Today

---

**Version 1.1 CMMI Product Suite was released January 2002.**

- CMMI Web site visits average 20,000/day
- Over 59,000 people have been trained
- Over 1600 “class A” appraisals have been reported to the SEI

**Now we want to continuously improve...**



# CMMI Books...

---

A Guide to the CMMI: Second Edition

CMMI: A Framework...

CMMI Assessments

CMMI Distilled: Second Edition

CMMI SCAMPI Distilled

CMMI Survival Guide

CMMI: Un Itinéraire Fléché: Second Edition

De kleine CMMI

Interpreting the CMMI

Making Process Improvement Work

Practical Insight into CMMI

Real Process Improvement Using the CMMI

Systematic Process Improvement Using ISO 9001:2000 and CMMI

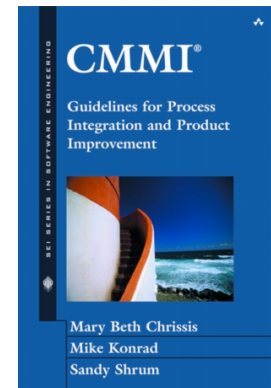

# How about SEI Publications?

---

Technical notes and special reports:

- Interpreting CMMI:
  - for Operational Organizations
  - for COTS Based Systems
  - for Service Organizations
  - for Marketing (in progress)
- Using CMMI with:
  - Earned Value Management
  - Product Line Practices
  - Six Sigma
- Supplementing CMMI for Safety Critical Development (in progress)
- Demonstrating the Impact and Benefits of CMMI (and web pages – [www.sei.cmu.edu/cmml/results](http://www.sei.cmu.edu/cmml/results))



# CMMI V1.2...and Beyond



Software Engineering Institute

Carnegie Mellon

© 2007 Carnegie Mellon University

# Major Themes

---

**Reduce complexity & size**

**Increase coverage**

**Increase confidence in appraisal results**



# CMMI Model Combinations

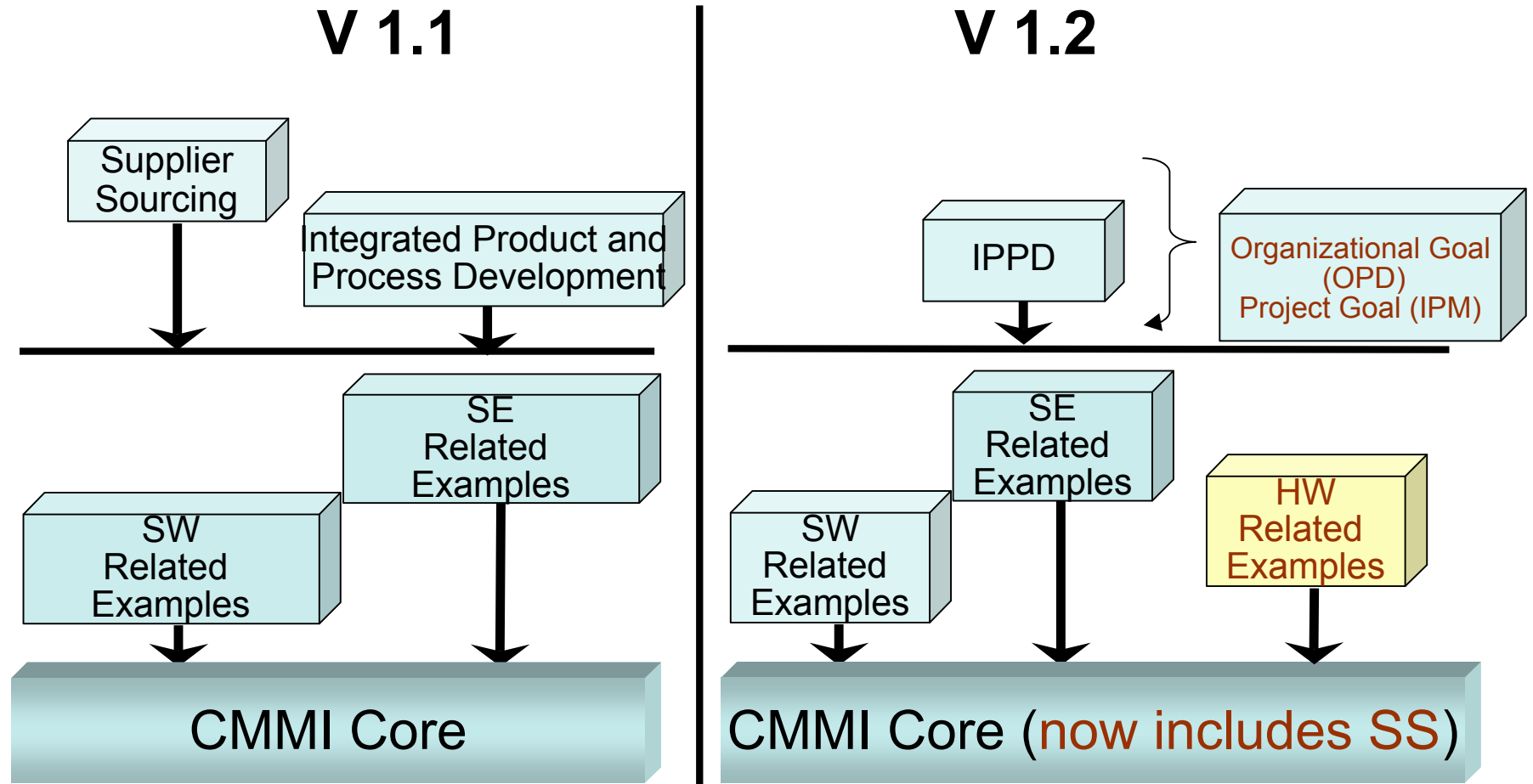

# IPPD Changes

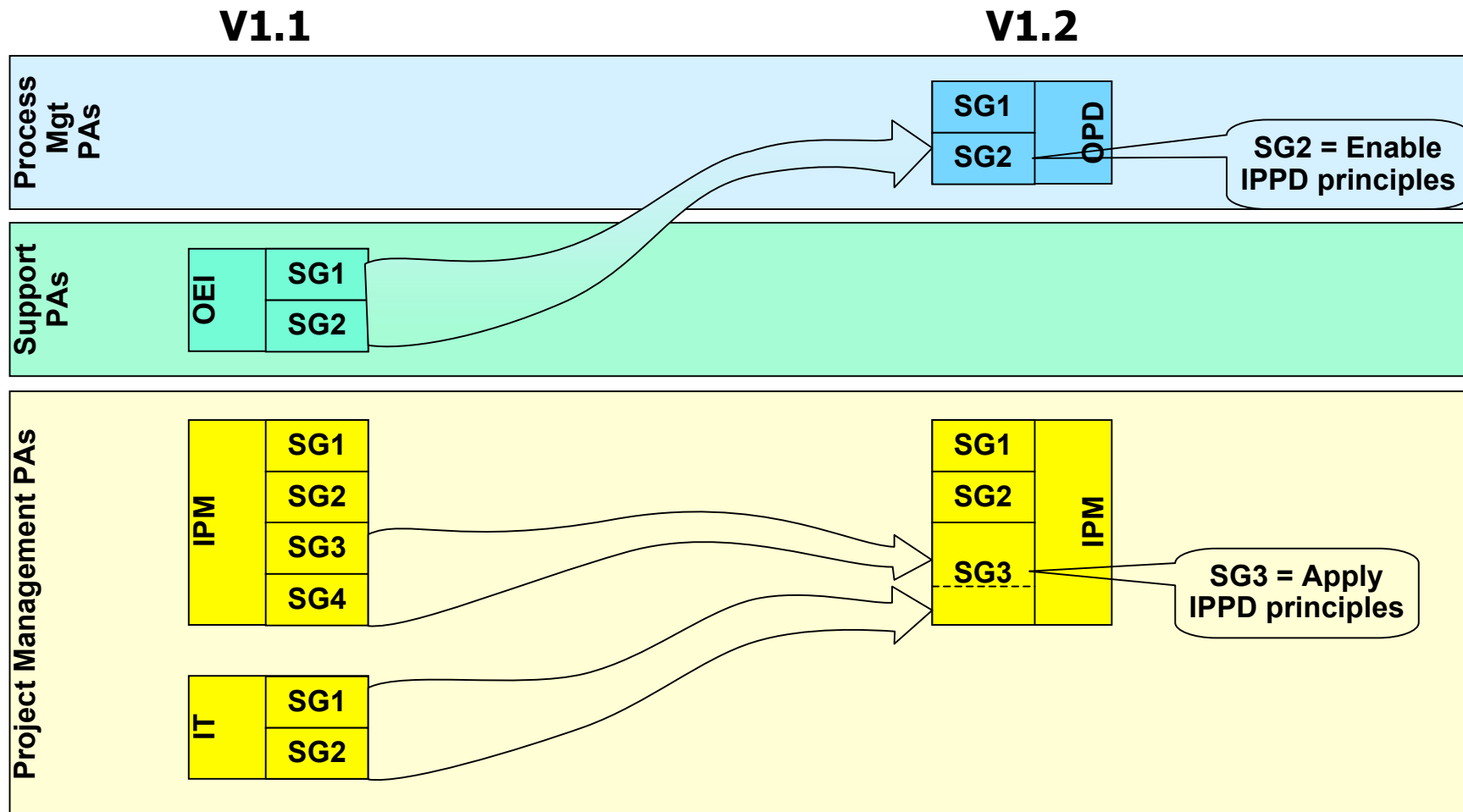

# SCAMPI A Changes for V1.2

---

## Method implementation clarifications

- interviews in “virtual” organizations
- practice characterization rules
- **organizational unit sampling options**

## Appraisal Disclosure Statement (ADS) improvements

- reduce redundancy with other appraisal documents
- improve usability for sponsor and government
- require sponsor’s signature on the ADS
- require all team members to show agreement on findings
- **Both V1,1 and V1.2 ADS will reflect these as of Nov 2006**

**Lead Appraisers must be “certified” to lead high maturity appraisals**

**Maturity level and capability level shelf life – 3 years, given 1 year of V1.2 availability**



# Published Appraisal Results



## List of Published SCAMPI Appraisal Results

**ORGANIZATION NAME:** Satyam Computer Services Ltd.  
**SPONSOR NAME:** Nagaraj Chevour  
**LEAD APPRAISER NAME:** Raghavan Nandyal  
**SEI PARTNER:** SITARA Technologies Pvt. Ltd.  
**APPRAISAL END DATE:** 4/3/2004  
**MATURITY LEVEL ASSIGNED:** 5  
**APPRAISED ORGANIZATIONAL UNIT:**  
     **Entity Name:** SRU GE-GDC  
     **Location(s):** Secunderabad, AP, India  
**CMMI MODEL USED:** CMMI-SWIPPD, V1.1, Continuous  
**APPRAISAL METHOD USED:** SCAMPI v1.1

### MODEL SCOPE & CAPABILITY RATINGS ASSIGNED:

Process Management	Project Management	Engineering	Support
OPF <span>Capability Level 3</span>	PP <span>Capability Level 4</span>	REQM <span>Capability Level 3</span>	CM <span>Capability Level 3</span>
OPD <span>Capability Level 3</span>	PMC <span>Capability Level 4</span>	RD <span>Capability Level 4</span>	PPQA <span>Capability Level 3</span>
OT <span>Capability Level 3</span>	SAM <span>Not Applicable</span>	TS <span>Capability Level 5</span>	MA <span>Capability Level 3</span>
OPP <span>Capability Level 3</span>	IPM <span>Capability Level 3</span>	PI <span>Capability Level 3</span>	DAR <span>Capability Level 3</span>
OID <span>Capability Level 3</span>	RSKM <span>Capability Level 4</span>	VER <span>Capability Level 5</span>	OEI <span>Capability Level 3</span>
	IT <span>Capability Level 3</span>	VAL <span>Capability Level 3</span>	CAR <span>Capability Level 3</span>
	ISM <span>Not Rated</span>		
	QPM <span>Capability Level 3</span>		



# CMMI V1.2 Schedules

---

<b>Version 1.2 CMMI Product Suite release</b>	<b>August 25, 2006</b>
<b>Update <u>material</u> available</b>	<b>August 25, 2006</b>
<b>Upgrade <u>course</u> available on-line</b>	<b>August 25, 2006</b>
<b>First Lead Appraiser “face to face”</b>	<b>October, 2006</b>
<b>First high maturity “oral exam”</b>	<b>October, 2006</b>
<b>V1.2 ADS required for all SCAMPis</b>	<b>November, 2006</b>
<b>Last V1.1 Intro training</b>	<b>December, 2006</b>
<b>First expiration of V1.1 appraisals (3 year validity)</b>	<b>August 25, 2007</b>
<b>Last V1.1 appraisal</b>	<b>August 31, 2007</b>



# Beyond V1.2

---

**Improved architecture will allow post-V1.2 expansion.**

- **Extensions of the life cycle (Services, Outsourcing/Acquisition) could expand use of a common organizational framework:**
  - **allows coverage of more of the enterprise or potential partnering organizations**
  - **adapts model features to fit non-developmental efforts (e.g., CMMI Services, CMMI Acquisition)**



# 3 Complementary “Constellations”

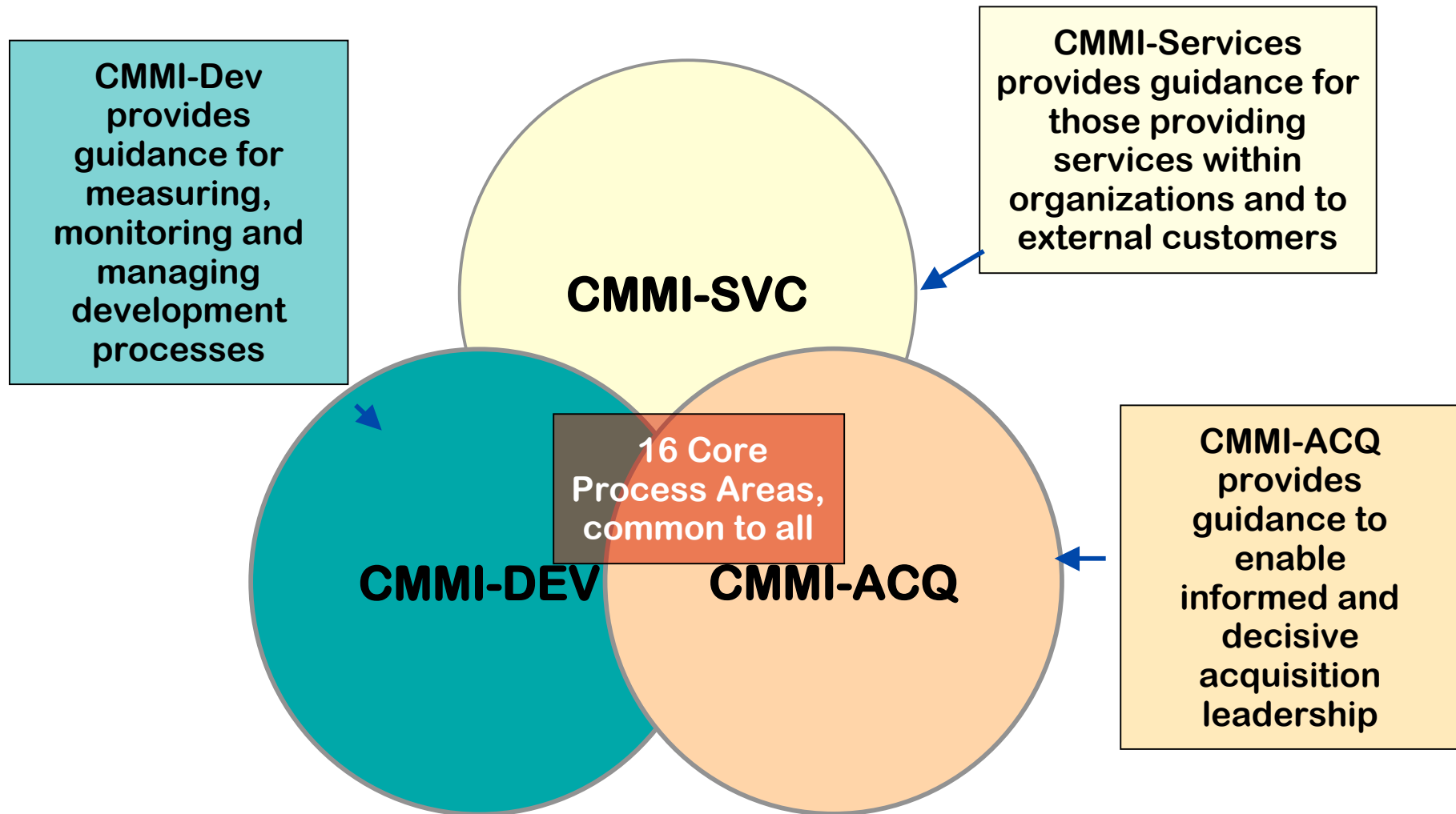

# Acquirer/Supplier Mismatch

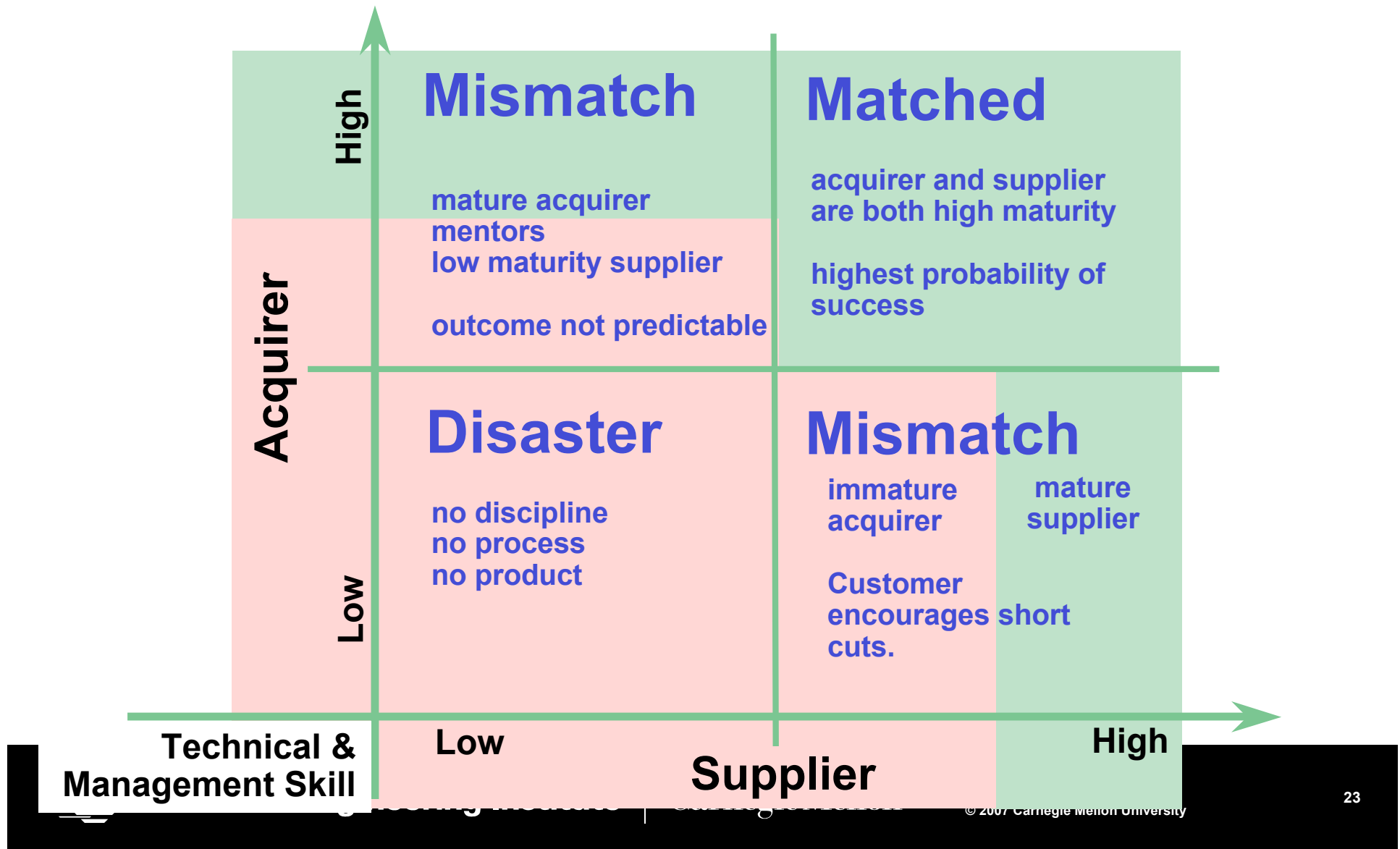

# Initial CMMI-ACQ Key Acquisition Processes\*

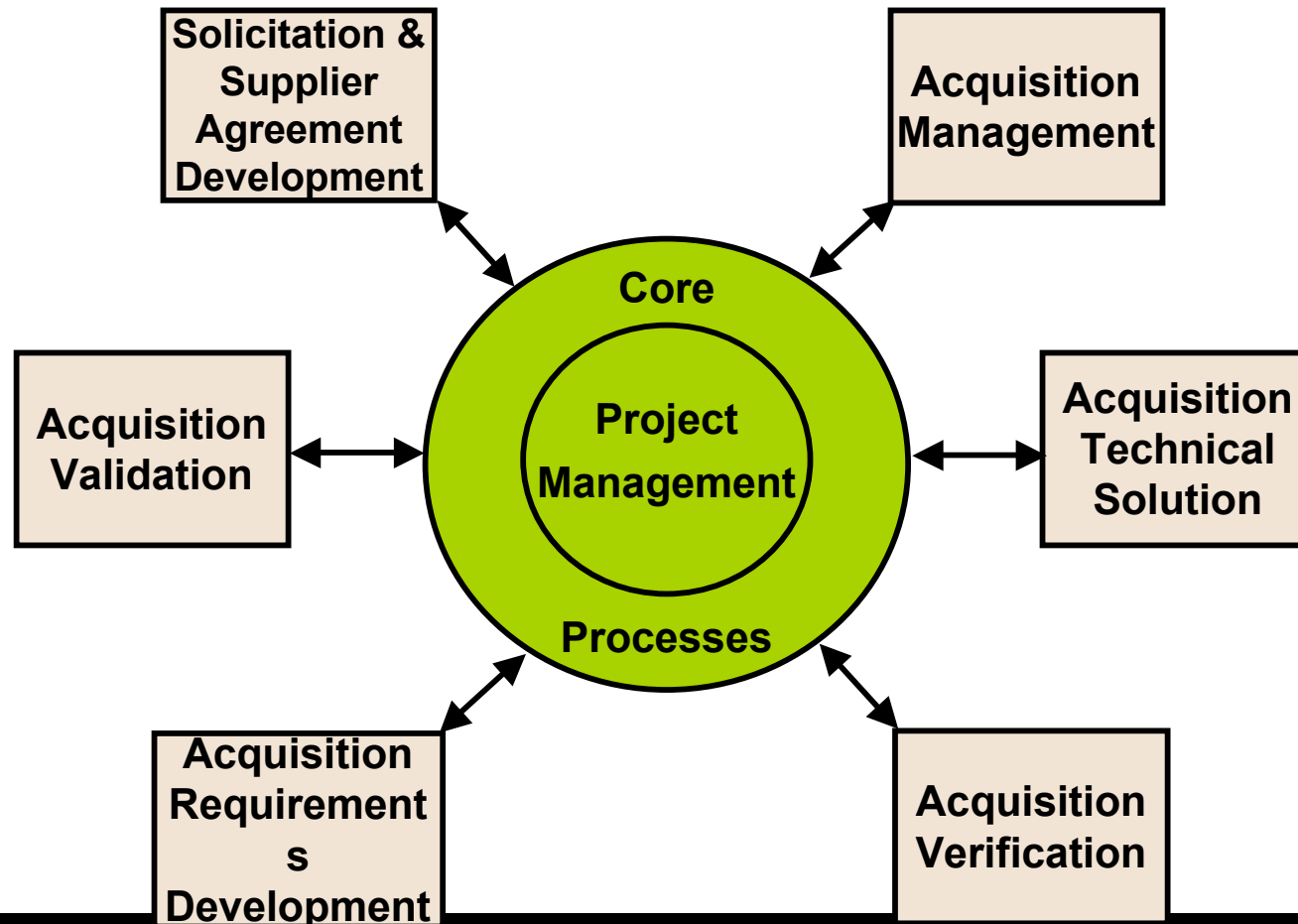

# Acquisition Improvement is needed....

Acquirers cannot ensure that mature processes are applied to their programs

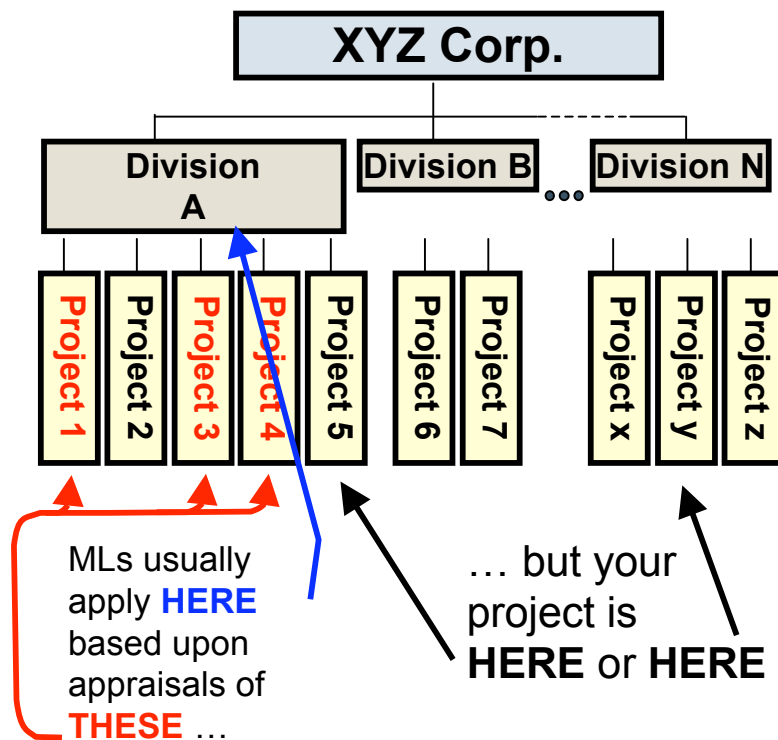

Acquirers need more internal process focus

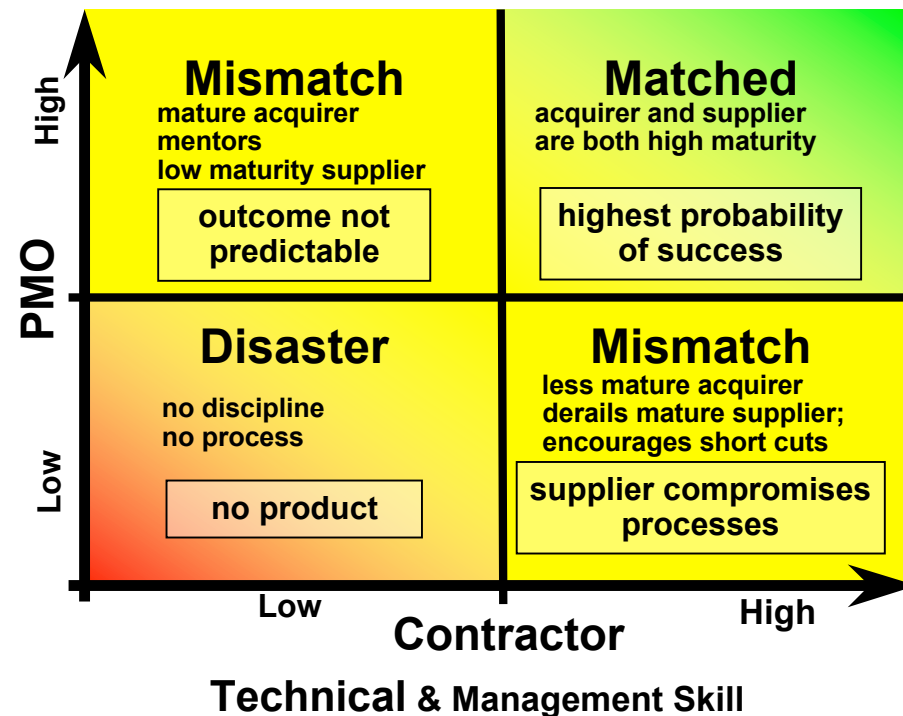

# Guidebook Concept

---

## Provide a “process toolbox” for the acquirer

- Include practical guidance on how to recognize the real practitioners...
- Encourage the use of capability and maturity profiles vice "single level" approach
- Improve acquisition organizations' understanding of the meaning of high maturity (levels 4 and 5) and equivalent staging
- Include multiple tools and guidance that may be used throughout the acquisition lifecycle



# Planned Sequence of Models

---

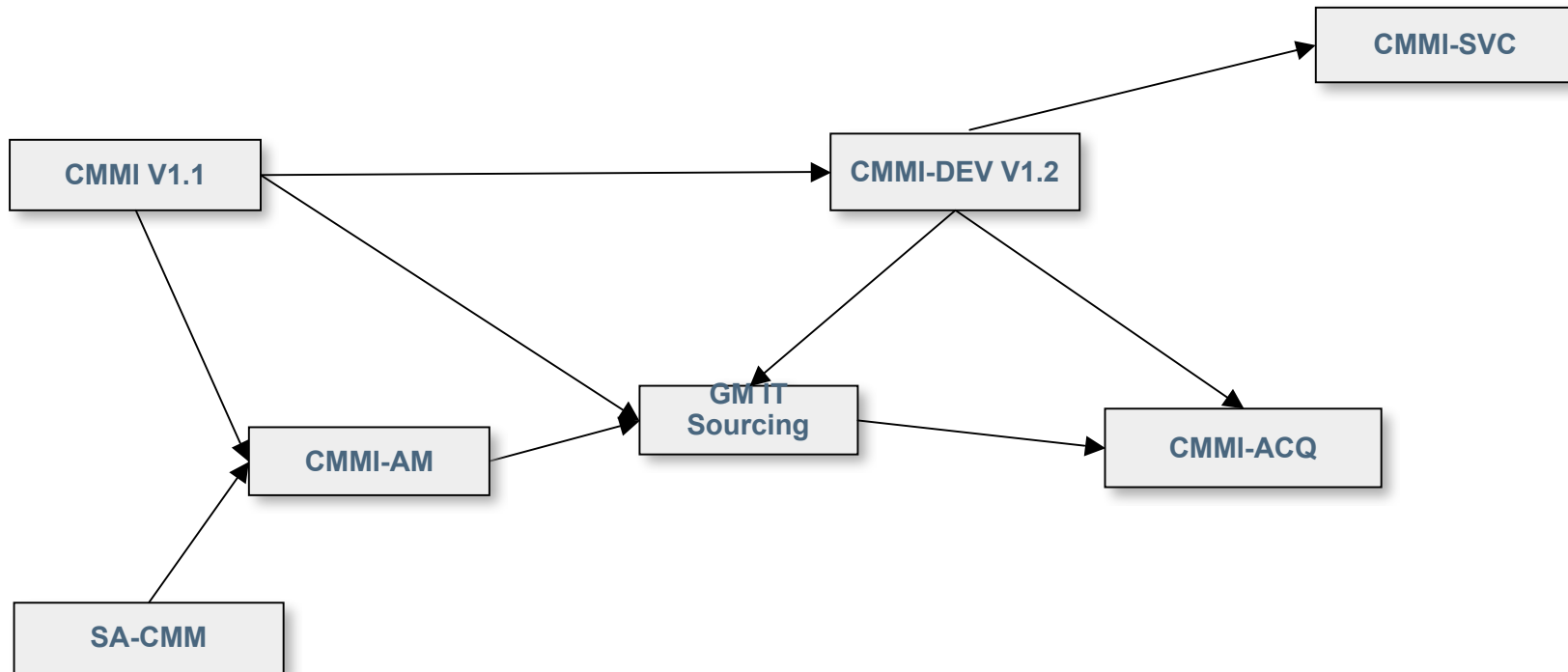

# Contact Information

---



**Jay Douglass**

[jcd@sei.cmu.edu](mailto:jcd@sei.cmu.edu)

**Direct +1 412 268 6834**

**Cell: +1 412 260 2445**

**Pittsburgh, Pennsylvania 15213**

